

X-Loupe® Inspection Task Lighting Product Parts and assembly diagram

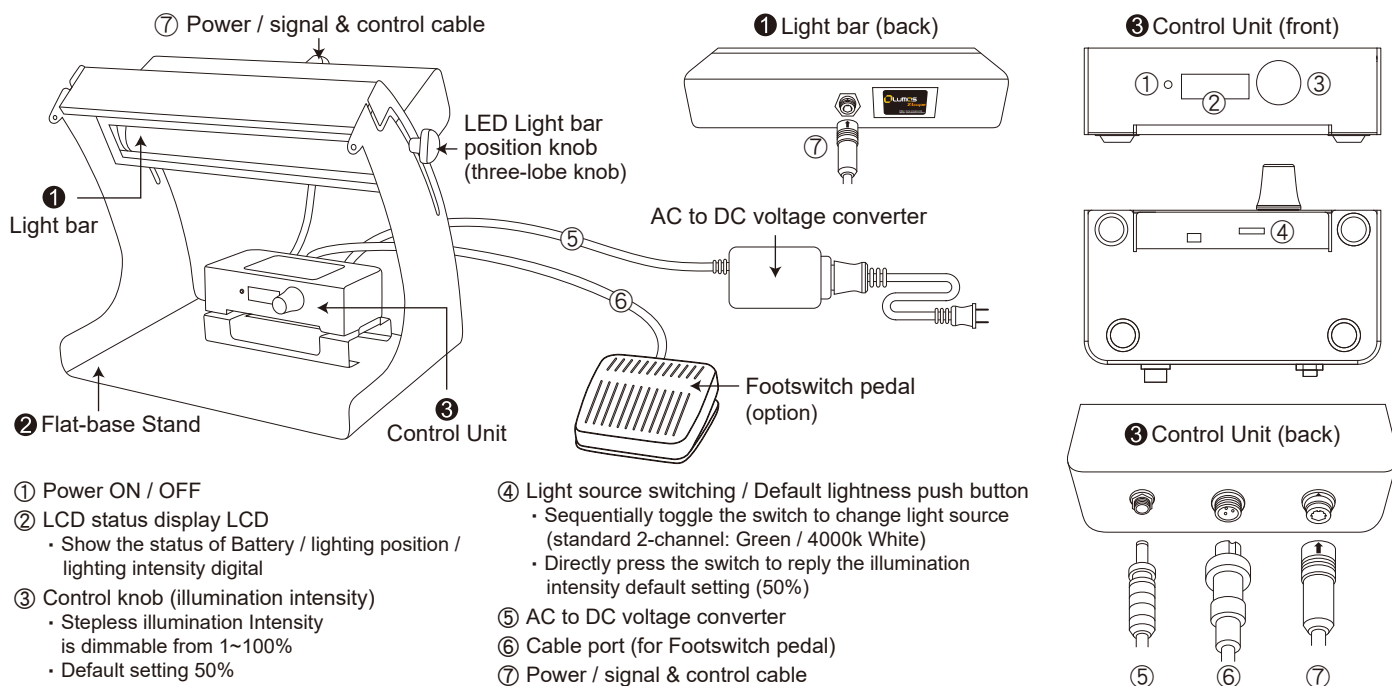

Installation instruction (I) Lamp Holder Set A (Light bar / Light shielding Plate to Flat-base Stand)

- From the upper entrance of sliding track get the Light Bar placed, as shown in Figure (1).
- Attach the gasket and the position Knob (for Light Bar) to the threaded rod protruding from light bar. Adjust the light bar to the desired position and tighten it, as shown in Figure (2).
- Place the metal plate on the top of the Flat-base Stand, align the screw holes and insert the 4 screws (Set A, Hexagon Socket Cap Screws) to the corresponding holes and tighten them, as shown in Figure (3).
- Insert the fixed knob (for light shielding plate) through the gasket; align the holes of light shielding plate to the upper holes on the sides of the flat-base stand, and then insert the fixed knob to the hole and tighten it, as shown in Figure (4).

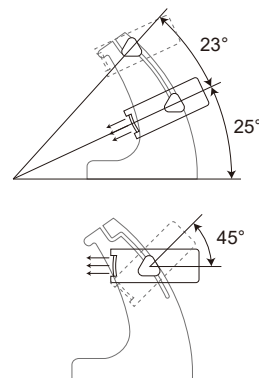
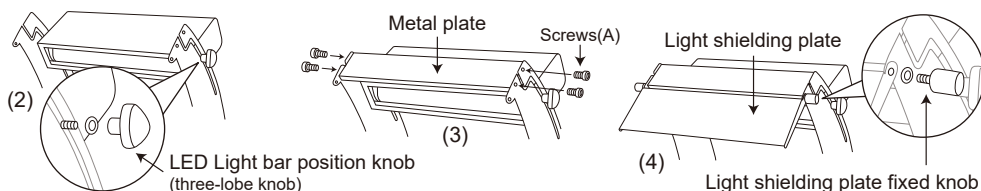

Note:
The illumination angle of the light bar on the bracket is adjustable (sliding track for up and down is about 23° / lighting bar is rotatable for 45°)

Installation instruction (II) Lamp Holder Set B (Control unit / Light bar / Light shielding Plate to Frame Bracket / VESA-mount Bracket)

< Combination for Control unit and Frame bracket >

- Remove the lower right screws (Set B, Cross recessed Flat-Head Screw) from tapped holes of the left and right sides of the Control unit as shown in the Figure(5); place the Control unit on the top of the frame bracket, reinsert another set of screws (Set C, Hexagon Socket Cap Screws) to the corresponding holes and tighten them. **(Note: Keep the two screws of Set A for next use)**

< Combination for Light Bar / Light shielding plate and Frame bracket >

- Insert the threaded rod protruding of light bar to the hole on the sides of the frame bracket as shown in the Figure(6). Attach the gasket and the position Knob (for Light Bar) to the threaded rod protruding and tighten it.
- Insert the fixed screw (for light shielding plate) through the gasket; align the holes of light shielding plate to the upper holes on the sides of the frame bracket, and then insert the fixed screw to the hole and tighten it.

< Combination for Lamp Holder Set B and VESA-mount Bracket >

- Align the screw holes on the back of assembled frame bracket to the rack hole of the VESA-mount Bracket (hole patterns: 100x100mm), and then insert the screws (Set D, Hexagon Socket Cap Screws) to the hole and tighten it.

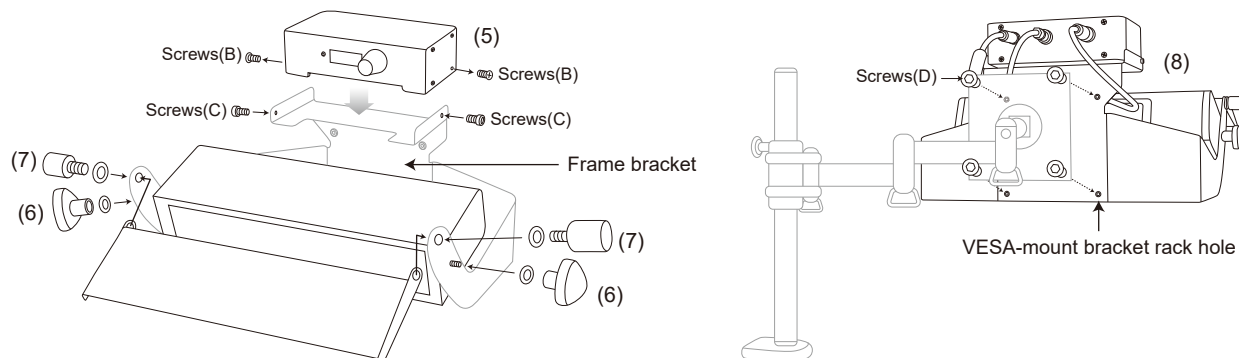

X-Loupe® Inspection Task Lighting Specification

Lamp Holder Set (c / w Light Bar and Control Unit)

Control Unit		
Function	Power On, Off / Light Channel Switch / Lighting & Dimming Control	
LCD Status Display	Battery check / Lighting Position / Lighting Intensity (0 ~ 100%)	
Power input	DC 19V / 4.7A	
Charging method	With the Power adapter (DC 19V / 4.7A) included in the product set to charge via a wall outlet	
Material	Steel, Aluminum	
Weight	545g	
Dimension(mm)	155 (L) x 115 (W) x 50(H)	
Power cable length	30 cm	
Operation Environment	0~40°C	
Light Bar		
Channel & Light source	Switchable dual light source channels 4 LED wavelengths (4000k White, Amber, Blue and Green colors) are available for users to choose from (choose 2 from 4)	
Dimming intensity	Intensity is dimmable from 1% to 100% (default setting 50%)	
Power Consumption	21W (Max)	
Power input	DC 80.2V / 0.25A	
Illuminance	(White light : distance 0 cm) Intensity (default) setting 50% : luminance > 4500lux ; Intensity setting 100% : luminance > 8000lux	
Dimension (mm)	320 (L) x 111 (W) x 58 (H)	
Weight	1580g	
Material	Stainless Steel (#304)	
Operation Environment	0~40°C	
Bracket		
	Flat-base Stand	VESA-mount
Material	Stainless Steel (#304)	
Weight	2200g	850g
Dimension (mm)	357 (L) x 295 (W) x 280(H)	357 (L) x 200 (W) x 160(H)

*We (Lumos Tech.) reserves the right to change the product appearance or specification. The contents of catalogs / manuals are subject to change without prior notice.

Precautions for use

⚠ Warning ⚠

Read all instructions and understand the warnings prior to using this product.

Failure to read and follow these safety instructions could result in fire, explosion, electrical shock or other hazard causing serious and/or fatal injury and/or property damage. Please obey the following instructions.

- 1.This product is not a toy. Keep out of reach of children.
- 2.This device equipped high-brightness excitation LEDs; it is intense enough to injure eyes. While operating, for eyes safety, DO NOT look directly excitation light source, or stare the leak of light at close range.
- 3.DO NOT leave this device near the heat source or use in a hot environment; The device has ventilation holes to prevent the internal temperature from becoming too high. Pay attention to the running of cooling fan. DO NOT block the ventilation hole/vent hole of cooling fan.
- 4.Keep the device away from water or other liquids. A humid device could result in fire or electric shock. If it's wet, immediately turn off the device power, then wipe out the liquid the device surface.
- 5.Turn off the LED lights when you aren't using them.
- 6.Refer all servicing to your distributor. Servicing is required when the device has been damaged in any way, such as power-supply cord is damaged, liquid has been spilled, the apparatus has been exposed to rain or moisture, does not operate normally, or has been dropped. Do NOT disassemble, alter or modify to this device.

Distributor



7th floor, No.8, Wanhe St., Wenshan District,
11653 Taipei City, Taiwan, R.O.C.
TEL:886-2-2230-1168 FAX:886-2-2239-2112
e-mail: contact@lumos.com.tw
www.x-loupe.com

Lumos Technology Co. Ltd.